

ART. 895#02A10

DN	D	K	d	B	H	N. holes	T
10	90	60	21	14	14	4	3
15	95	65	25	14	14	4	3
20	105	75	31	16	14	4	4
25	115	85	38	16	14	4	4
32	140	100	47	18	18	4	5
40	150	110	53	18	18	4	5
50	165	125	65	20	18	4	5
65	185	145	81	20	18	4 o 8	6
80	200	160	94	20	18	8	6
100	220	180	120	22	18	8	6
125	250	210	145	22	18	8	6
150	285	240	174	24	22	8	6
200	340	295	226	24	22	8	6
250	395	350	281	26	22	12	8
300	445	400	333	26	22	12	8
350	505	460	365	30	22	16	8
400	565	515	416	32	26	16	8
450	615	565	467	36	26	20	8
500	670	620	519	38	26	20	8
600	780	725	622	42	30	20	8

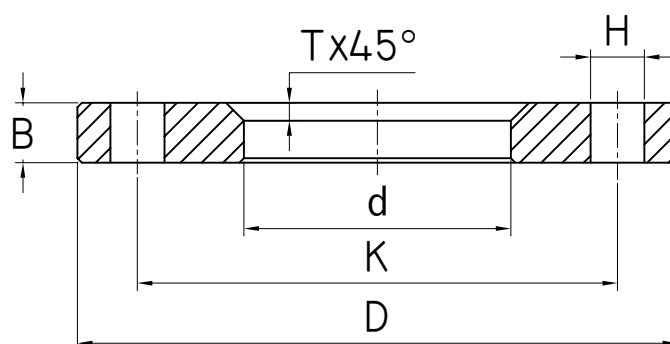

FLANGIA ASTM A182 EN 1092-1 02A PN 10
 FLANGE ASTM A182 EN 1092-1 02A PN 10

TECNICATRE
 Stainless Steel Experience